

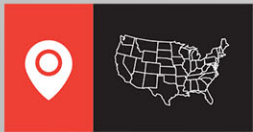

2017 **NXP-450** *SELECTIVE* *SOLDERING SYSTEM*

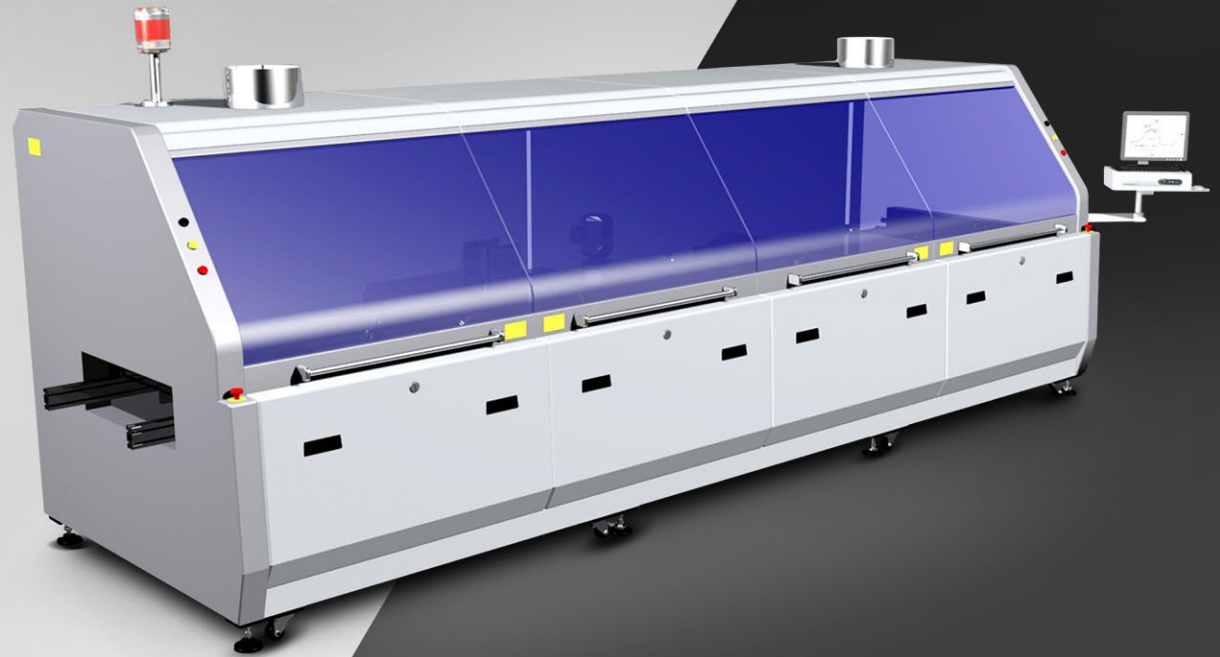

USA

10030 Via de la Amistad, San Diego, CA 92154
Phone: +1 (619) 661-5985 **Fax:** +1 (619) 661-5995
Email: ams@ams-fa.com



Brazil

Estrada Municipal Mario Covas, 641 Cond. Industrial Portal Anhanhuera
Macuco - Valinhos / SP, Brazil 13279 - 411 **Phone:** +55 (19) 2511-4943
Email: quote@ams-fa.com



AUTOMATION. SMT & LEAN MANUFACTURING

www.ams-fa.com

Our Wave Soldering machine has **3** systems:

1 **Spraying System**

2 **Preheating System**

3 **Soldering System**

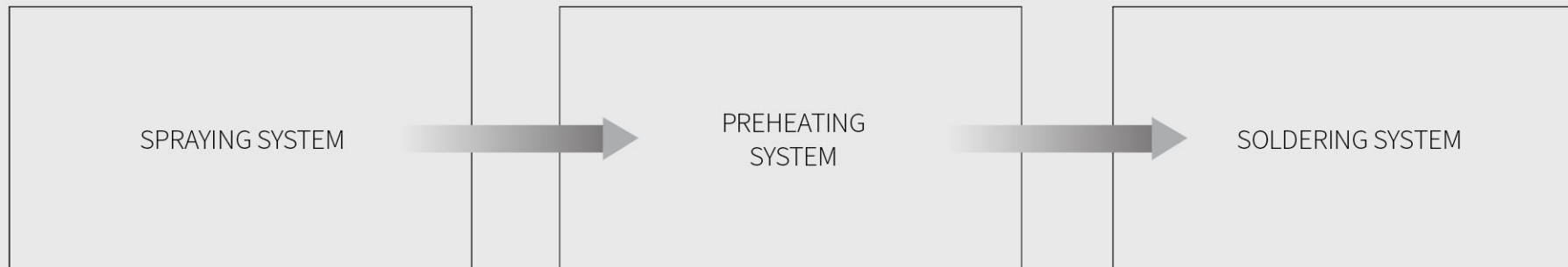



- 1** High Accuracy
- 2** Stable and Reliable
- 3** Production efficiency and easy maintenance
- 4** Available offline programming



- 5** Uses two zones hot air for the top pre-heating system.



- 6** Adopted CCD camera to monitor solder processing, the soldering quality can be traced in whole processing.



- 7** Selective flux spraying can control the flux processing accurately as well as keeping the clear surface of PCB with extremely low flux consumption.

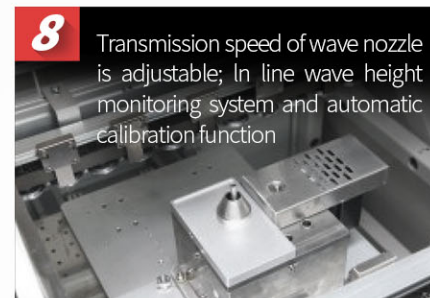

- 8** Transmission speed of wave nozzle is adjustable; In line wave height monitoring system and automatic calibration function



- 9** The temperature controls for top and bottom preheating is independent. Cs lamp heating can improve heating efficiency and temperature uniformity.

- 10** Lead Free Acceptable

- 11** Through-hole soldering flexibility; single point, drag, mini-wave, or dip soldering

- 12** Production capacity and investment costs can be flexibly adapted to meet actual needs through this consistent modular design

- 13** Precise axis system for accurately positioning the individual workstations

- 14** Maximum flexibility with quick-change solder nozzles, wettable or non-wettable depending on your application

- 15** Unbeatable price/performance ratio



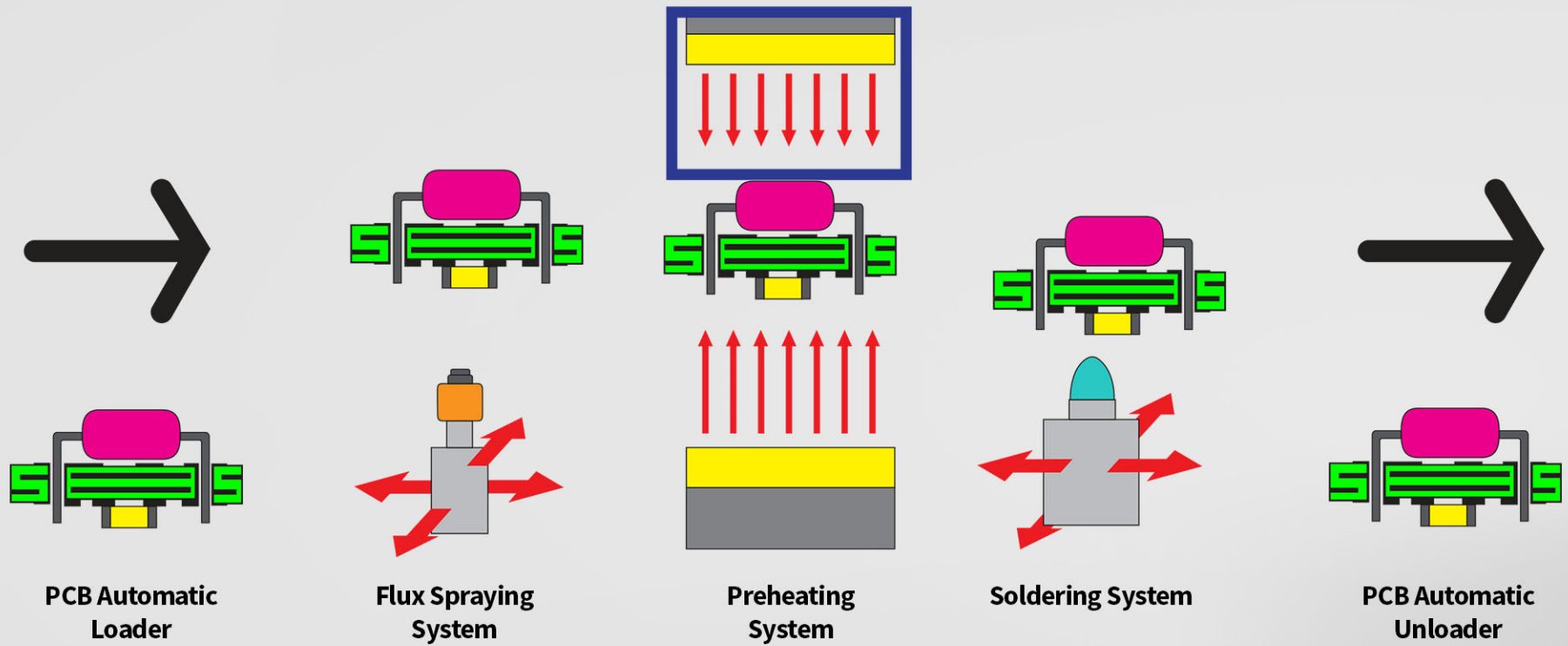



The flux spraying system adopts fixedness pressure stainless steel pot with filter device to drive the flux to the spraying nozzle. The high frequency spraying nozzle starts to work controlling by pulse signal. Flux is sprayed like a bullet. The flux consumption can be controlled accurately by pulse signal and width.

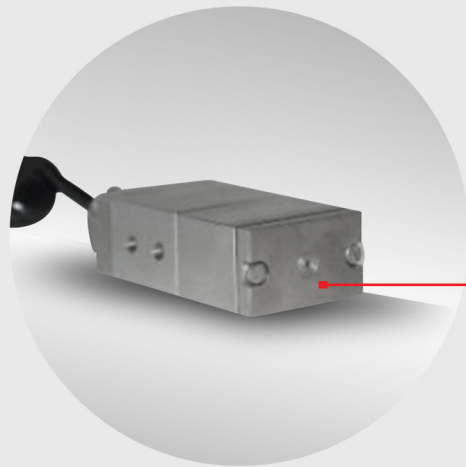

High frequency spraying nozzle made in Germany

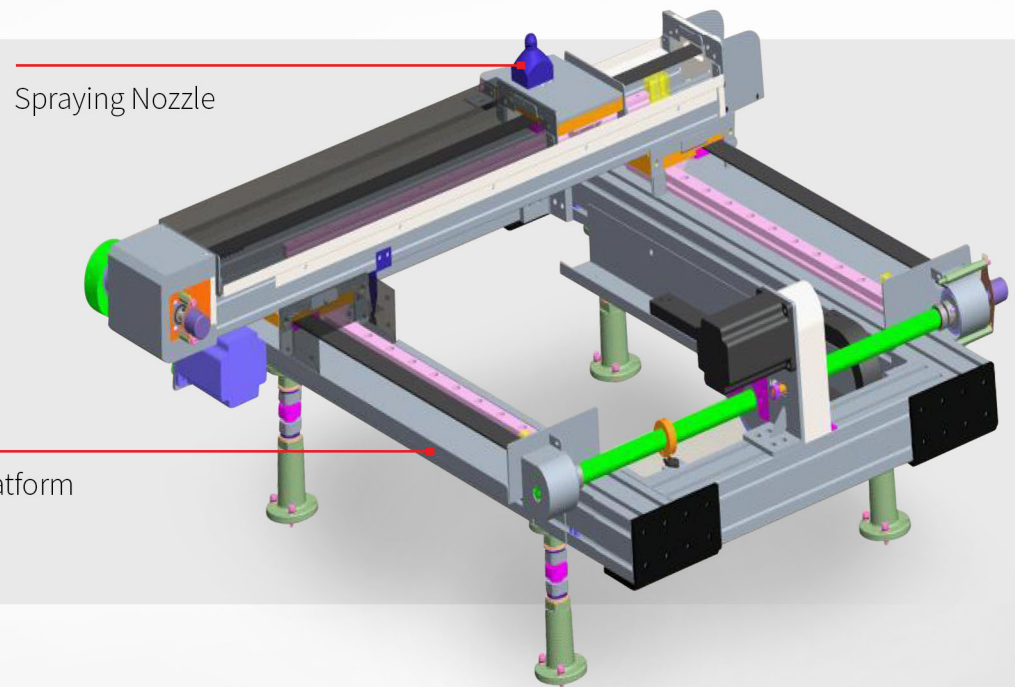

Spraying Nozzle

X-Y Platform

■ The temperature controls for top and bottom preheating is independent, Cs lamp heating can improve heating efficiency and temperature uniformity.

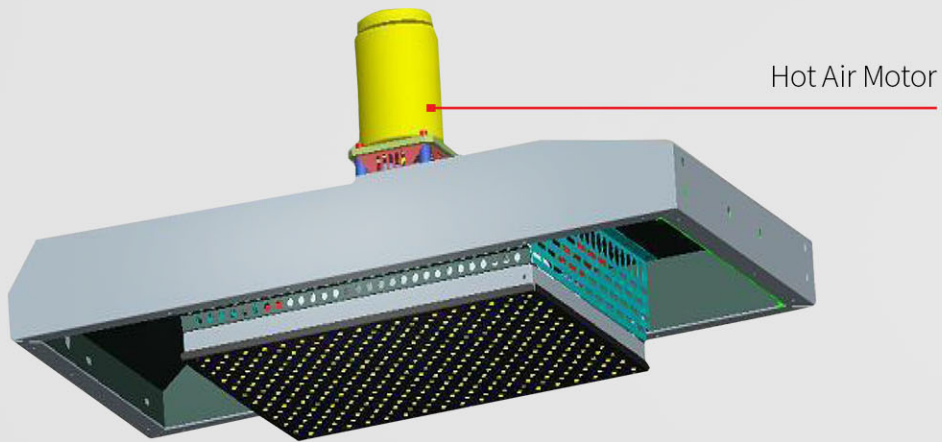

Top Preheating

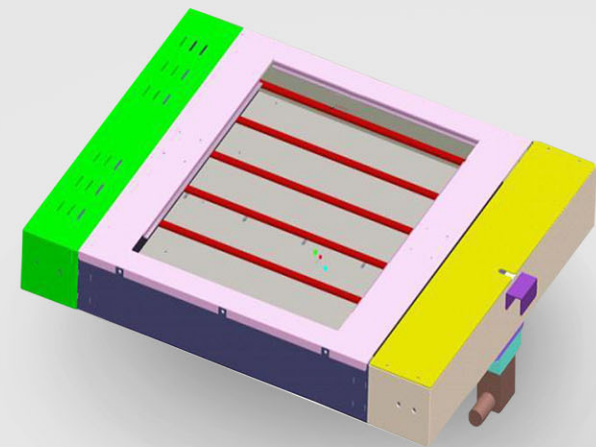

Bottom Preheating



The point soldering pot is driven to the position where is needed by X-Y-Z platform accurately. It can solder both single point and multi-point. The soldering nozzle can be made according to customer's requirement.

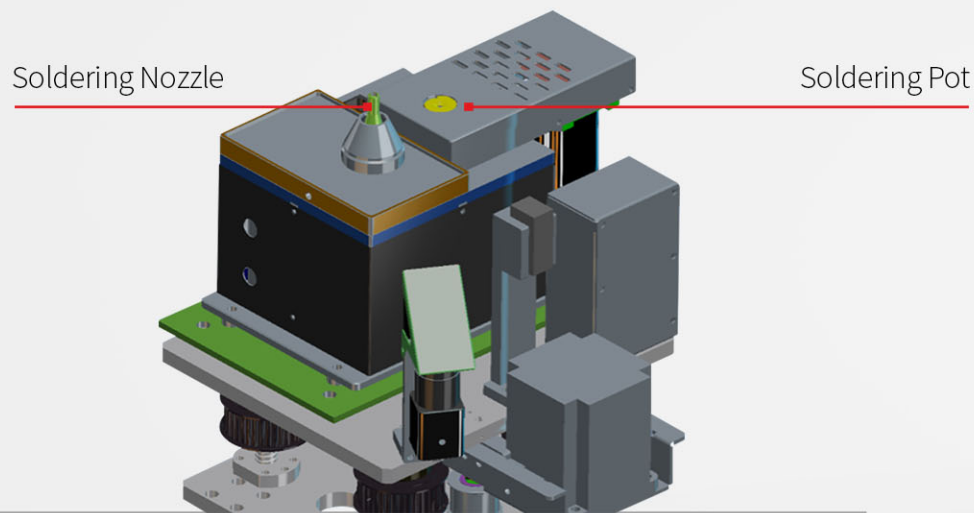

Point Soldering Module

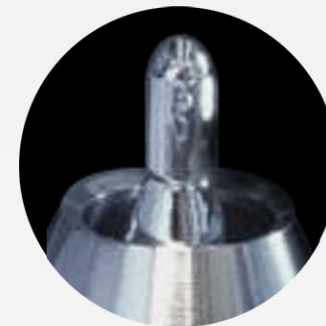

** Wave shape & spraying nozzle*

Soldering Nozzle Adopted CCD camera to monitor solder processing, the soldering quality can be traced in whole processing.

Offline programming software is included and can be used either with Gerber or JPG's, inputting the x and y coordinates. There is no need to interrupt production to make new programs.

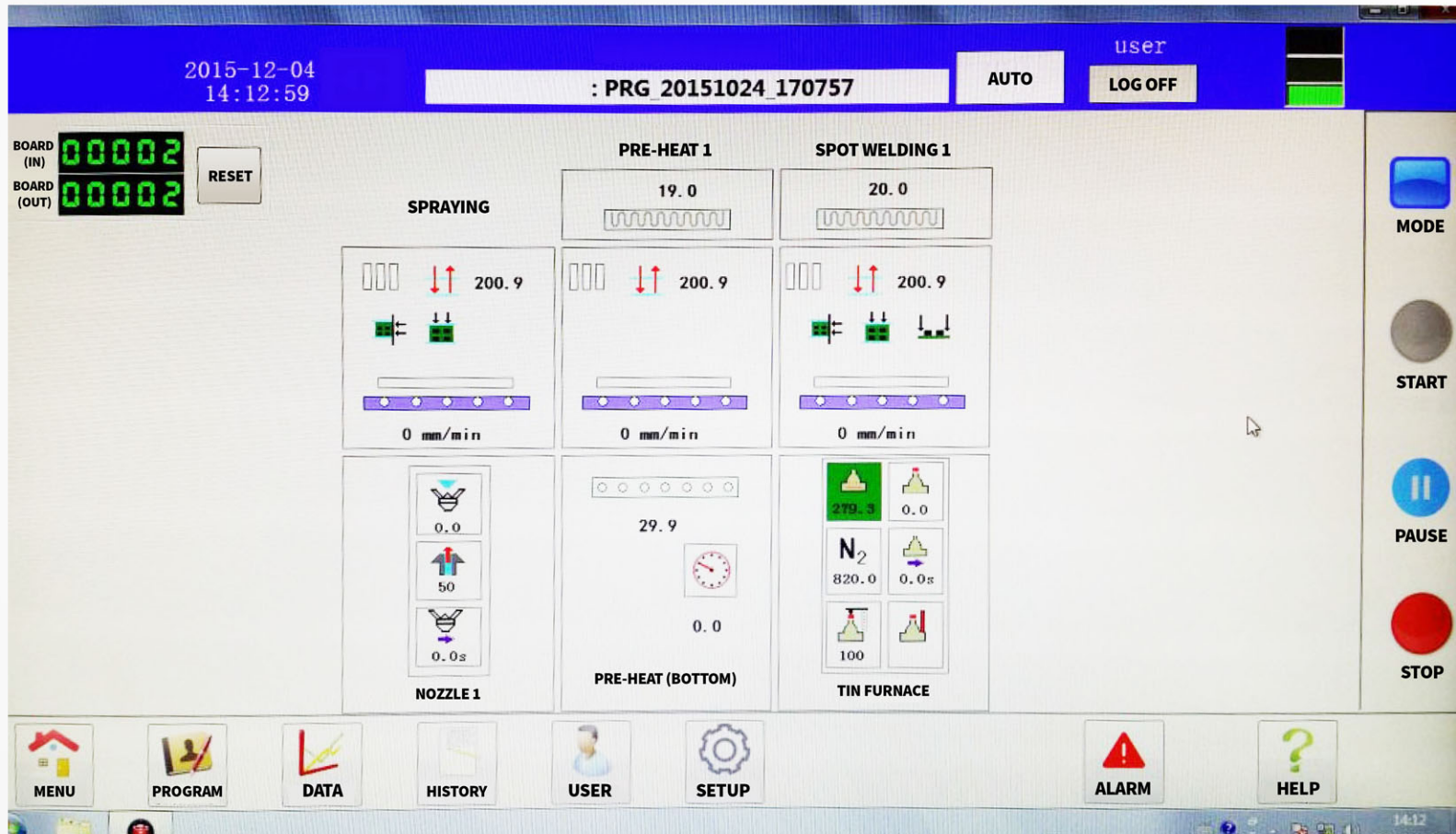



Energy saving and environmental protection: Compared with the traditional wave soldering, our machine can save more energy and save you production costs.

COST COMPARISON SHEET

Item	Traditional Wave Soldering	Our Selective Wave Soldering	Notice
Oxidized tin per hour	0.65kg	0.05kg	
Fluxed consumption per hour	0.6kg	0.03kg	
Nitrogen consumption per hour	24m ³	2m ³	
Power consumption per hour	13KW	6KW	

** We can get a conclusion: Selective wave soldering can save more cost of producing productions from the sheet.*

Items	Specification
Min. PCB Size	L 120mm x W 60mm
Max. PCB Size	L 550mm x W 450mm
PCB Thickness	0.5 ~ 6mm
PCB Weight	Max. 5kg
PCB Upper Space	Max. Upper 100mm
PCB Down Space	Bottom 50mm
PCB Process Edge	4mm
Board Handling System	
Conveyor System	3 independent zone with independent control, chain and special turn plate
Conveyor Height	850+/-50mm
Width Adjustment	60mm to 460mm
Width Adjustment Accuracy	+/-0.2mm
Conveyor Direction	Left to right / right to left
Preheating System - Bottom Side	
Pre-heating Temperature / Power	Max. 160° C (PCB surface) / Max.18kw
Temperature Control Accuracy	+/-2°C @3 sigma / Cpk≥1.33
Heater	Philips Cesium light, Independent control
Heating Area	L 650mm x 580mm
Preheating System - Top Side	
Preheating Temperature / Power	Max. 160° C (PCB surface) / Max.8kw
Temperature Control Accuracy	+/-2°C @3 sigma / Cpk≥1.33
Heater	Hot air, Independent Control
Fluxing System	
Fluxer Nozzle	Micro drop jet fluxer
Fluxing Wet Area	Ø2 mm to Ø5mm
Flux Types	Alcohol or Water based
Fluxing Controller	Automatic level control with capacitive sensor
Selective Position Method	X-Y Platform
Position Speed / Accuracy	Max.400mm/s, +/-0.25mm
Flux Container	3L pressure tank
Soldering Unit for Soldering Processes	
Solder pot compatible for Lead-Free Soldering	Standard
Nitrogen Operation	Standard
Automatic Wave Height and Solder Level Control	Standard
Automatic Wire Solder Feeder	Standard
Wettable and Non-Wettable quick change nozzles	Standard
Solder Bath Temperature	300°C
Temperature Control Accuracy	+/-2°C @3 sigma / Cpk≥1.33
Solder Pot Capacity	12kg lead free
Wave Height	Max. 5mm
Solder Pot moving speed	Max. 400mm/s
Soldering Nozzle Dimensions	Ø5 to Ø12mm (or customized)
Control System	
Power Supply	380VAC, 3 P, 50 / 60Hz, 52A
PCB Data Import	GERB file, Offline file import, Image program
Programming Interface	Windows Interface
Power	35kw

